

PATTERN 10

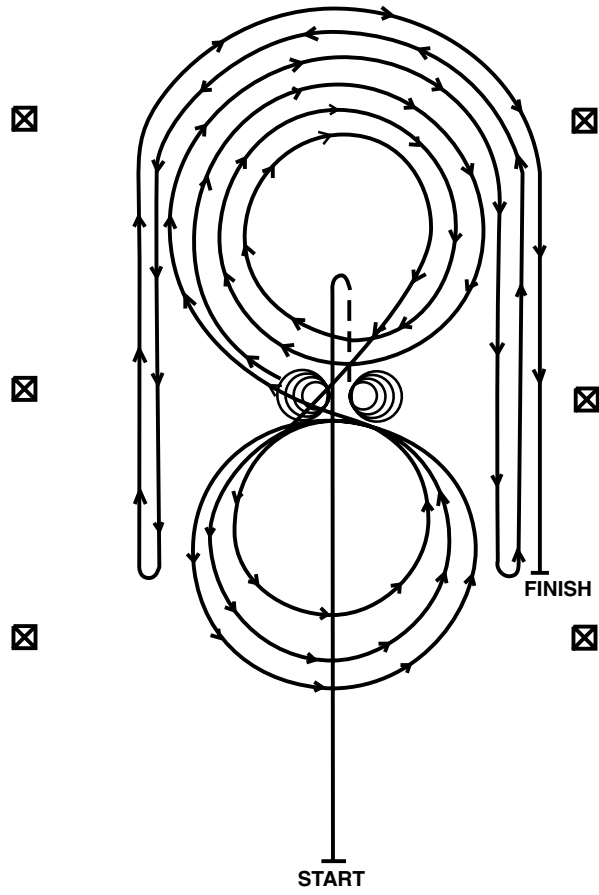

PATTERN 10

1. Run past the center marker and do a sliding stop. Back up to the center of the arena or at least ten feet. Hesitate.

2. Complete four spins to the right.

3. Complete four and one-quarter spins to the left so that the horse is facing the left wall or fence. Hesitate.

4. Beginning on the right lead, complete three circles to the right: the first two circles large and fast, the third circle small and slow. Change leads at the center of the arena.

5. Complete three circles to the left: the first circle small and slow, the next two circles large and fast. Change leads at the center of the arena.

6. Begin a large fast circle to the right but do not close this circle. Run down the right side of the arena past the center marker and do a left rollback at least twenty feet from the wall or fence - no hesitation.

7. Continue back around the previous circle but do not close this circle. Run down the left side of the arena past the center and do a right rollback at least twenty feet from the wall or fence - no hesitation.

8. Continue back around previous circle but do not close this circle. Run down the right side of the arena past the center marker and do a sliding stop at least twenty feet from the wall or fence. Hesitate to demonstrate completion of pattern.

Rider must dismount and drop the bridle to the designated judge.